

Your excellent helper in cable test!

Your excellent helper in cable test!

NF-9816



**OTDR Optical Time
Domain Reflectometer
User Manual**



VER:V2

Introduction

Thank you very much for purchasing and using this series of hand-held optical time domain reflectometer. This manual mainly contains the common operation and maintenance information of the instrument, as well as the common troubleshooting guide. For your convenience, please read this manual carefully before operating the instrument, and follow the instructions in this manual correctly.

This manual is only used in conjunction with this instrument. Any unit or individual shall not tamper with, copy or disseminate the content involved in this manual for commercial purposes without the authorization of the Company.

The contents of this manual are subject to change without prior notice. If you have any questions, please call the supplier, we will be happy to provide you with the best quality service!

Overview

This series of optical time domain reflectometer is a multi-functional optical measuring instrument, integrating automatic OTDR, expert OTDR, event map, 10G split wave optical power meter, end state verification, multi-core test, stable light source, optical power meter, optical loss test, network line length, line sequence test, network line hunting, optical fiber end detection, wireless charging and other functions in one. Touch screen and button double design, simple operation, friendly interface, is the optical cable construction installation, engineering acceptance and on-site repair of the right hand.

Warning

When using this instrument, do not look directly at the laser output or the end of the optical fiber with your eyes, so as to avoid eye damage or even blindness!
Non-online test wavelength, forced use of light will cause damage to the internal components of the instrument!
Making any changes or modifications that are not expressly permitted in this Manual will cause you to lose the right to operate the equipment.
To reduce the risk of fire or electric shock, do not expose this device to thunderstorms or damp conditions.
In order to prevent electric shock, do not open the shell, and must be repaired by qualified personnel designated by the manufacturer.

Notice

Battery and adapter: The battery inside the machine is a special polymer lithium battery, the charging voltage is 5V/1A, the charging temperature range is 0 °C ~ 50 °C, the charging will automatically stop when the ambient temperature is too high. The instrument is recharged once every 1 month to avoid long storage time, and the battery cannot be used normally due to self-discharge. The temperature range of the battery for long-term storage is -20°C ~ 50°C.
Please use the special adapter that comes with the instrument, and use the external power supply in strict accordance with the specifications, otherwise it may cause damage to the equipment.
Optical fiber end face cleaning: Before testing, clean the end face of the measured optical fiber connector of the access instrument with an alcohol cotton.
LCD screen: The display of this series of instruments is 4.3 inch color LCD, in order to maintain a good viewing effect, please keep the LCD clean and clean. When cleaning, the LCD screen can be wiped with a soft fabric.

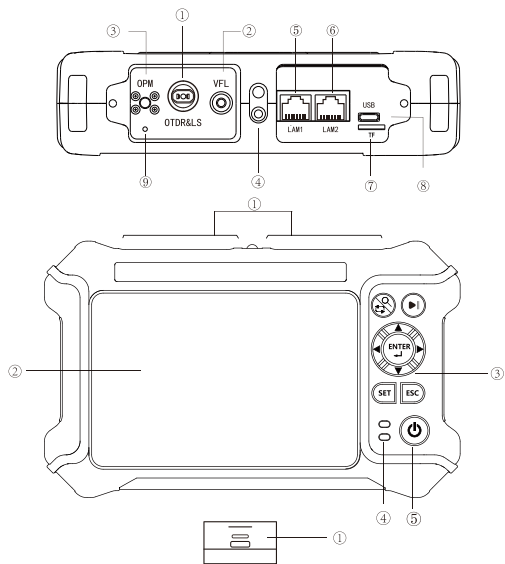

Top

- ① OTDR/LS port
- ② VFL (Red Light) port
- ③ OPM (Optical power meter) port
- ④ Flashlight
- ⑤ RJ45 Cable length/sequence port
- ⑥ RJ45 Cable Tracker port
- ⑦ TF (Micro SD) card slot
- ⑧ Type C USB (Charge/connect computer to copy data)
- ⑨ host reset button

Main view

Main view

- ① Dust cover
- ② 4.3 color LCD
- ③ Function key
- ④ Power on/charge indicator
- ⑤ On-off key

End

- ① RJ45 Sequence test remote

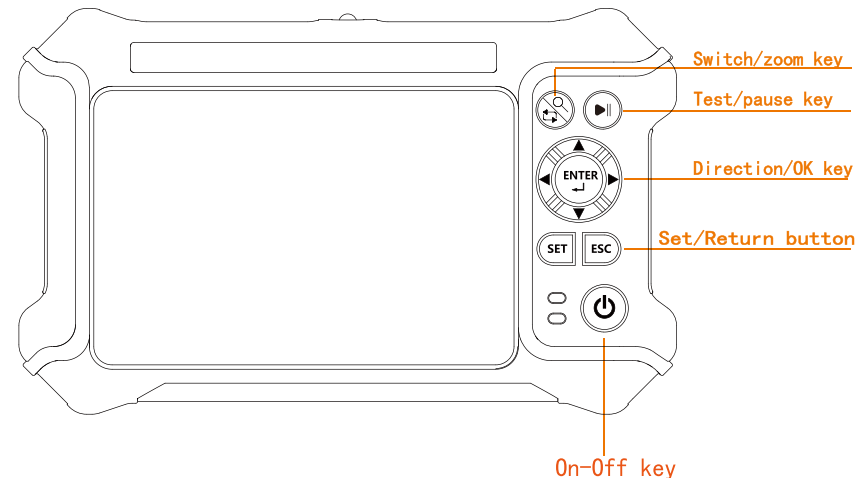

Switch/zoom key

Test/pause key

Direction/OK key

Set/Return button

On-Off key

Press the Set/Return button for 2s to power on, and long press to pop up the power-off confirmation window.

After booting up, enter the main menu, press the directional keys to select the function module, and then press the "ENTER" key or directly touch the screen to press the corresponding function icon to enter the function interface.

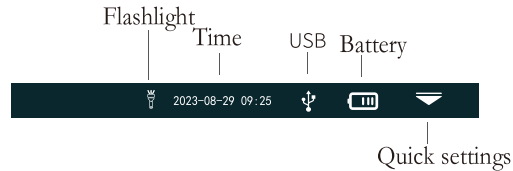

Press the Quick Setting icon to enter the Quick operation menu. Press different function ICONS to enter the corresponding function interface or implement the corresponding operation function.

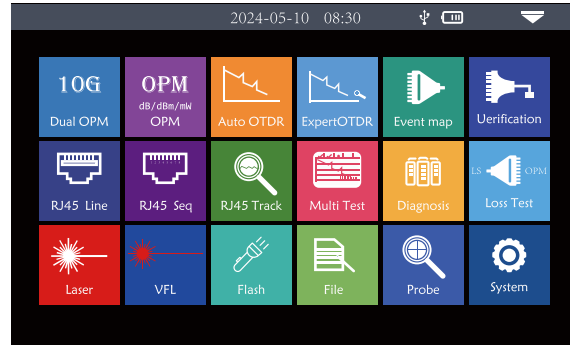
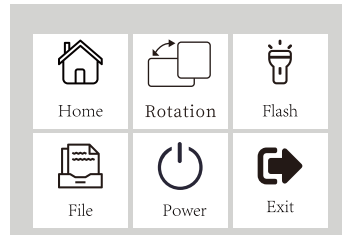

The split-wave optical power meter is mainly used for commissioning, installation and maintenance of the 10GEPON/XGPON FTTx service. It not only has the function of a general optical power meter, but also has a downlink 1490nm and 1577nm wavelength split power measurement designed for 10GEPON/XGPON, and displays the respective power values of the two wavelengths on the same screen, which can truly grasp the power value of a single wavelength optical signal on the line, and can accurately determine whether the optical power value is up to standard.

Reference: Set the current power to the reference power

Calibration: Enter calibration mode

Zero setting: Zero reference power

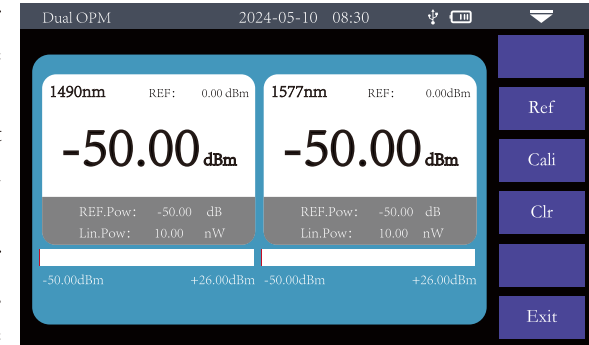

It is used for signal power test and insertion loss test of various equipment and photoelectric components.

Wavelength: Switch the test wavelength of the power meter.

Reference: Set the current power to the reference power.

Calibration: Enter calibration mode.

Threshold: Set the power measurement threshold. If the power measurement threshold is higher than the threshold, the power measurement threshold is marked in red and the power measurement threshold is lower than the threshold, the power measurement threshold is marked in green.

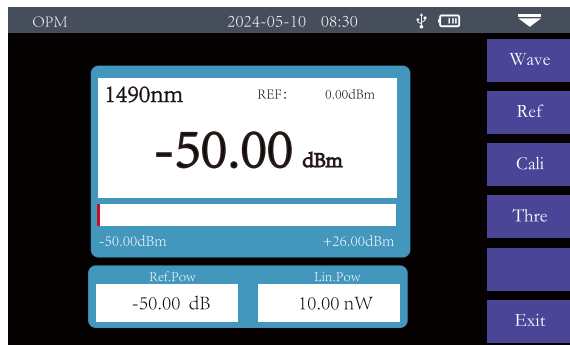

Absolute power, relative power and linear power values are converted as follows:

$$P_{\text{Absolute power}} = 10 \lg P_{\text{linear power}} / 1\text{mW},$$

$$P_{\text{Absolute power}} = P_{\text{Absolute power}} - P_{\text{reference power}}.$$

OTDR is a photoelectric integrated instrument made of Rayleigh scattering and Fresnel reflection generated by the backscatter of the optical signal transmitted in the optical fiber. It is widely used in the maintenance, construction and monitoring of optical cable lines. It can measure the optical fiber length, optical fiber transmission attenuation, joint attenuation and fault location.

Automatic OTDR: Just set the wavelength and measurement time, and other parameters are automatically selected by the instrument to complete the test.

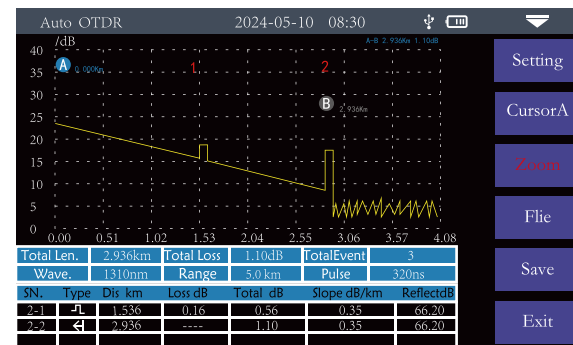

Notice

Please do not make online test except online wavelengths!

Expert OTDR: Parameters such as wavelength, measurement range and pulse width need to be set.

In expert mode, the appropriate measurement parameters are selected, and the test results are more accurate. The curve can be zoomed in to see the details of each event.

In expert mode, you can select "Real-time Test", "Average Test", and "Automatic Test" according to the actual requirements of customers.

Notice Please do not make online test except online wavelengths!

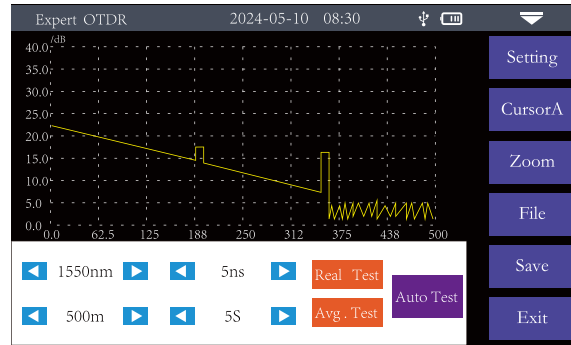

Measurement wavelength: The test wavelength is selected according to the actual wavelength of the machine.
 Measurement range: Select the corresponding length range according to the actual length of the optical fiber. It must be greater than the length of the optical fiber under test, and is usually set to about twice the length of the optical fiber under test.

Pulse width measurement: refers to the time width of the optical pulse signal emitted during measurement, the larger the pulse width, the stronger the optical power injected into the fiber, the stronger the backscattered signal of the fiber, the farther the OTDR can effectively detect, but the large pulse width will cause the initial reflected signal saturation, resulting in a large blind area. The choice of pulse width is related to the length of the measured fiber.

Measurement time: The measurement time in the average measurement mode, the longer the detection time, the better the signal-to-noise ratio improvement of the signal, the more accurate the test results. The user should reasonably choose the measurement time, and the measurement time is proportional to the measurement dynamics.

Event loss threshold: Set the loss threshold of the connection point, weld point, or macro bend that can be tested. The value ranges from 0.2dB to 30dB. The default value is 0.25dB.



Reflection threshold: Set the return loss threshold of the link reflection events that can be tested. The value ranges from 10dB to 60dB. The default value is 40dB.

End threshold: Set the loss of the end of a link that can be tested. The value ranges from 1dB to 30dB. The default value is 10dB.

Index of refraction: determined by the characteristics of the fiber itself and provided by the cable or fiber manufacturer, the index of refraction is a key parameter for calculating distance and cannot be set arbitrarily.

Unit: Required unit, km/kft/mi.

Curve scaling

Press the "Curve Scaling" menu to enter the zoom and zoom modes.

◀ / ▶ Zoom in or out on the X-axis

▲ / ▼ Y-axis zoom in or out

Event list

Total length: Indicates the total length of the link under test

Total loss: Indicates the total loss of the link under test

Test wavelength: Indicates the measurement wavelength used by the link under test

Range: Indicates the measurement range of the link under test

Pulse width: The measured pulse width used by the link under test

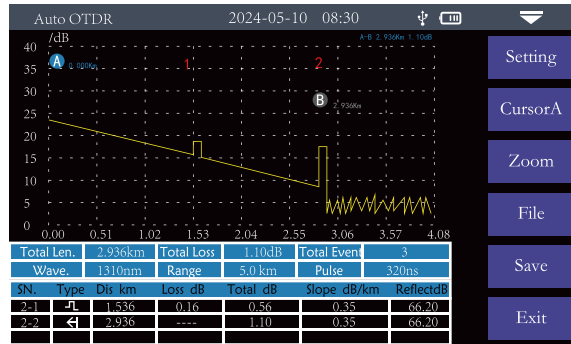

In the event list

Serial number: Indicates the sequence of current events

Type: Indicates the type of the current event point

Distance: The location of the current event point

Loss: The loss value of the current event point

Total loss: The cumulative loss value of the current event point

Slope: Loss per kilometer from the starting point to the current event point

Reflection: The return loss value of the current event point







File operation

By default, the test data file is saved in the local machine (TF card). When saving, you can select the save location through the pop-up option.

Press File to enter the file operation window. You can search for, open, and delete files.

Directory	File List	Total Files: 4	Open
Local	SN: Name Date		
2023/11/06	<input type="checkbox"/> 1 otdr0.sor 2023/11/06 14:45		Prev. Page
2023/11/07	<input checked="" type="checkbox"/> 2 otdr1.sor 2023/11/06 14:45		Next Page
2023/11/08	<input type="checkbox"/> 3 otdr2.sor 2023/11/06 14:45		Check All
2023/11/09	<input type="checkbox"/> 4 otdr3.sor 2023/11/06 14:45		Delete
2023/11/10			Exit
2023/11/11			

The function is completely one-click automatic test, the length of the optical fiber link under test, the connector type, the breakpoint position and other information is displayed in a graphical form, and the results are clear and easy to understand.

-  — The start point of a link after the front end is added to the guide fiber
-  — Most of the falling events are welding points
-  — Rise event, caused by inconsistent refractive index of two sections of fiber
-  — Connector, flange, SC, ST, LC connector, etc
-  — Fiber macrobend
-  — Link end

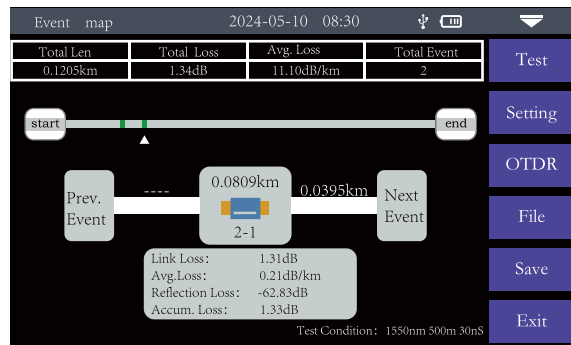

Notice Please do not make online test except online wavelengths!

Intelligent check the status of optical network terminal resources, and only judge the terminal connection status of the client ONT line in the corridor fiber box without entering the house, meet the needs of on-site port release and resource data verification, and achieve fine management of network resources. At the same time, the link loss between the splitter and the client is measured for low light diagnosis.

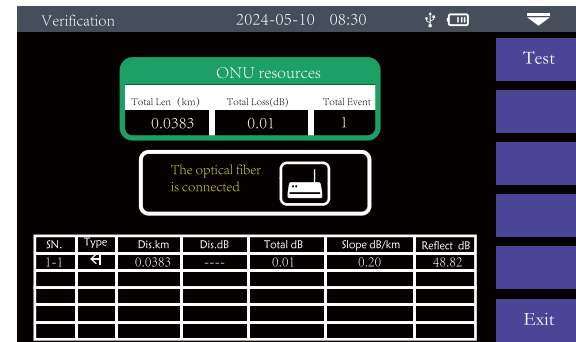

Cable length test: Tests the length of the network cable.

Calibration: Corrects the measured length of the network cable.

Network cable standard: T568A/T568B. The color sequence of the network cable varies according to the standard.

Line sequence measurement: Connect the remote module at the bottom of the instrument when testing. There are two types of RJ45 connector cables: straight line and cross line.

Through line test: During the test, the port display of the host and remote test terminal should be displayed sequentially from 1 to 8.

Cross-line test: During the test, the ports of the host are displayed in sequence from 1 to 8, and the ports of the remote test side are displayed in order of 3, 6, 1, 4, 5, 2, 7, 8.

Notice

The line length/line sequence interface is specified as the left interface of the instrument displayed in yellow. Do not damage the equipment due to wrong connection!

Warning

Please cut off the electricity before test

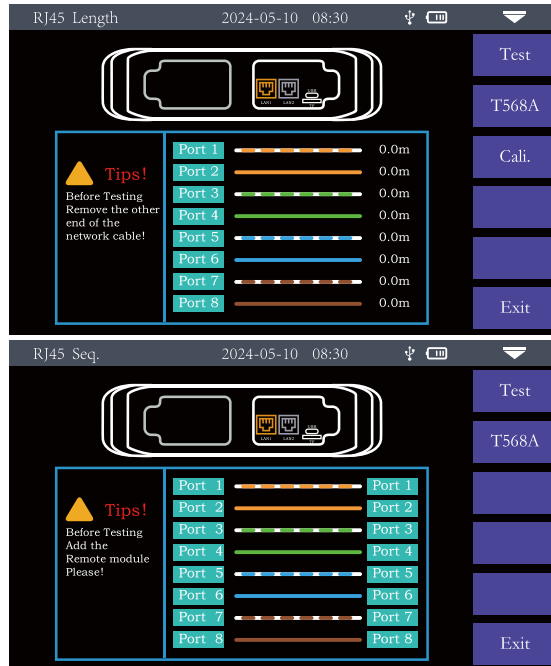

RJ45 hunting test

After the line hunting function is enabled, touch the cable under test with the line finder and hear the continuous "drip, drip" sound to find the cable.

The equipment can withstand pressure and fire, and can be directly charged line hunting. Ethernet switches, routers and other weak current devices with DC voltage less than 60V.

Test: Turn on the RJ45 hunt function

The hunting mode of the machine is digital radar hunting, which has strong anti-interference ability. The frequency of the prompt tone is different according to the distance of the target.

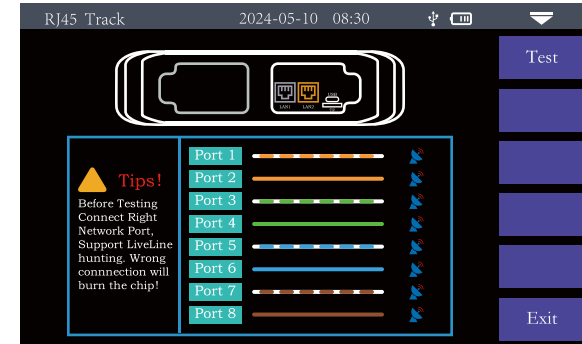

Notice

The hunting interface is specified as the interface on the right side of the instrument displayed in yellow. Do not damage the equipment due to wrong connection!

1. When a multi-fiber cable is tested, the newly constructed project ---- project name ---- number of fiber cores (based on the number of fiber cores currently tested) ----Enter confirm -- new project.
2. Open the project -- Select the project name -- Working project -- select the corresponding test serial number to test one by one ---- You can test/replace/view the next page.
3. When each core test is completed, the corresponding icon turns green.

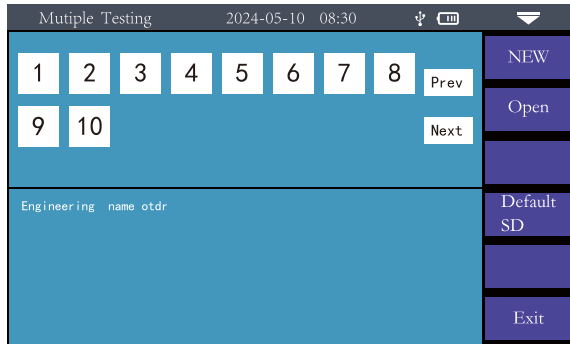

The light source and power meter are displayed at the same time, which is convenient for testing the insertion loss, isolation and return loss of optical passive devices.

Optical loss measurement steps are as follows:

- 1) Connect LS and OPM optical interface with standard jumper first, press [Open], after the power is stable, press [Reference].
- 2) Connect the tested part and read the "loss" value, that is, the insertion loss of the tested part.

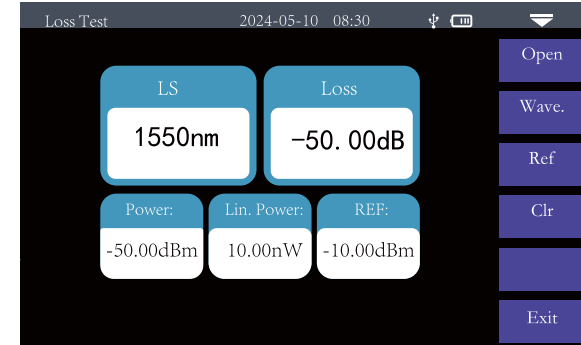

Stable light source and OTDR functional wavelength of the same laser, used in telecommunications, CATV, LAN cable parameter testing; Optical passive device insertion loss, isolation, return loss test; Detector wavelength responsiveness test and so on. There are five operating modes of the light source: CW, 270Hz, 330Hz, 1kHz and 2kHz.

On: Turn on the light source

Wavelength: Switch the wavelength of light source

Mode: Switch light source mode, CW, 270Hz, 330Hz, 1kHz and 2kHz



Warning

Avoid looking directly at the laser output port, laser will cause damage to human eyes!

By injecting visible light (red light) into the fiber and observing the light leakage position on the measured fiber, the location of the fault point of the fiber can be easily and accurately determined. It is suitable for the detection of bare fiber, fiber jumper and other fiber that can leak red light, near end fault point of fiber cable and high loss area caused by micro-bending.

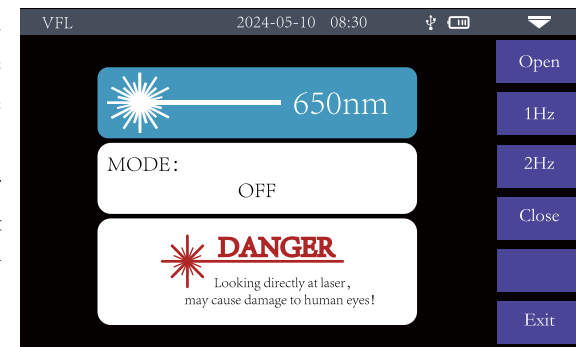

Warning

Avoid looking directly at the laser output port, laser will cause damage to human eyes!

Optical fiber end detection and cleaning is an important step to ensure the quality of optical fiber communication. The pollution or damage of optical fiber end face will lead to signal attenuation, reflection loss and unreliable connection. Therefore, regular detection and cleaning of optical fiber end face is crucial to ensure effective optical transmission. The USB interface end face detector suitable for this machine can detect and clean the end face of the test link to ensure the quality and reliability of link communication transmission.



Set information such as automatic shutdown, backlight brightness, and sound.

Automatic shutdown: OFF / 5 min / 15 min / 30 min / 45 min / 60 min

Backlight brightness:

10%/30%/50%/75%/100%

Sound: Turn on or off touch and key tone

USB connection: After opening, connect to the computer and transfer data

Language: Displays the native language type

Time Date: Set the instrument time and date

Restore factory Settings: Restore default parameter values

Firmware upgrade: Local software update

Version information: View the local information

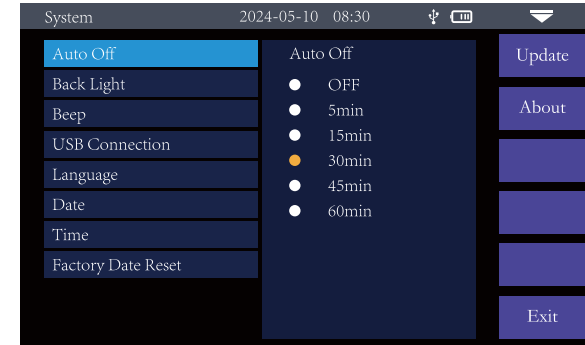

Fault description	Fault cause	Solution
The instrument does not start properly	The battery is dead	Charge the battery and observe the charging light. If it flashes, continue charging. Otherwise, contact the supplier
The instrument cannot be charged properly	The operating environment does not meet charging conditions	Charge the instrument in an environment ranging from 0°C to 50°C
	Battery problems, or internal circuit problems	Contact the supplier to replace the battery
No normal curve can be measured	Instrument parameters are not set correctly	Reset the correct test parameters
	The output end of the optical fiber is contaminated	Clean the optical output end face
	The optical output connector is damaged	Connect to output connector
	The optical output connector does not match	Replace the matching connector
The test curve has large burrs and uneven waveform	The output interface is incorrectly connected	Reconnect the appropriate output interface
	Pulse width setting braid small	Increase the test pulse width value
The front end of the test curve is saturated (flat top)	The pulse width setting is too large	Reduce the test pulse width parameter
The reflection peak at the beginning of the test curve drops slowly There is a tailing phenomenon	The output end of the optical fiber is contaminated	Clean the optical output end face
	The optical output connector is damaged	Replace the output connector
	The optical output connector does not match	Replace the matching connector
The optical fiber end reflection peak cannot be measured	The range setting is too small	Increase the test range value
	Pulse width setting is too small	Increase the test pulse width parameter
False positives in curve analysis	The test curve quality difference event threshold is set too small	Increase the test pulse width parameter and increase the event threshold
The measured fiber length is not accurate	Instrument parameters are not set correctly	Reset the appropriate parameters
	The refractive index setting of the optical fiber is incorrect	Reset the refractive index of the optical fiber
The measured average optical fiber loss is inaccurate	The front end of the test curve is too long	Clean the optical output end face
	The cursor point position is incorrectly set	Reset cursor point position.

Connector cleaning

The optical output interface of this series OTDR is a replaceable universal interface, and the end face must be kept clean during use. When the instrument is unable to test a normal curve, or the test results are inaccurate, the connector is first considered for cleaning.

When cleaning, be sure to do it with both OTDR and visual red light fault location turned off. Unscrew the output connector and wipe the end face with a special dust-free paper towel or cotton swab dampened with alcohol.

At the same time, after the instrument is used, please cover the dustproof cap, and keep the dustproof clean.

Instrument screen cleaning

The display of this series of optical time domain reflectometer is a 4.3-inch TFT full-view color LCD with capacitive touch screen. Sharp objects cannot be used to click the LCD screen when in use. If the LCD screen may be damaged, soft paper can be used to wipe and clean the LCD screen. Do not wipe the LCD with organic solvents; otherwise, the LCD may be damaged.

